

BOLTING DOWN HOLES

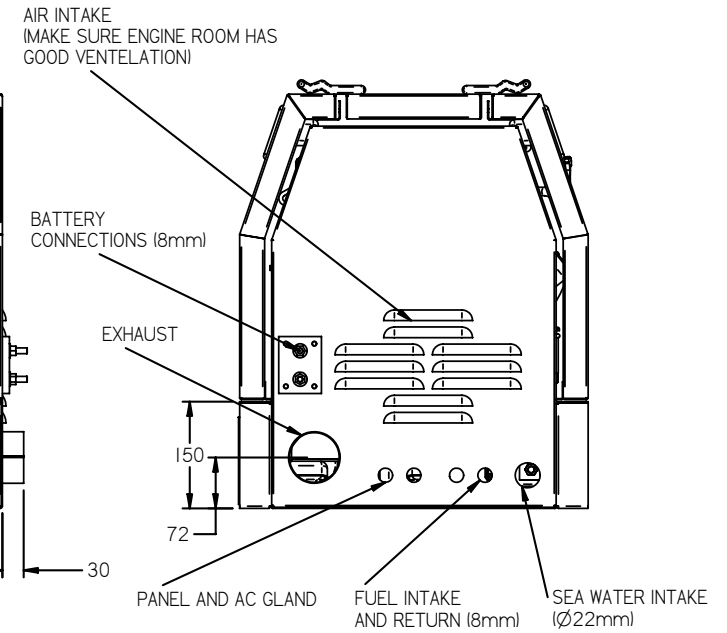
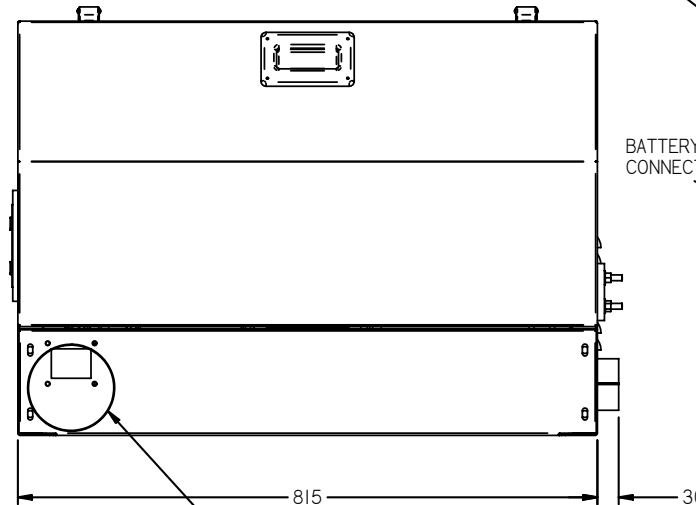
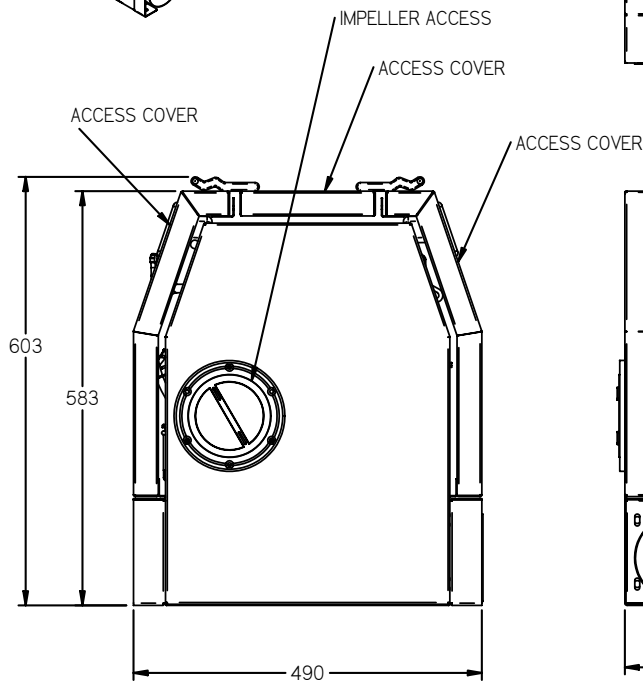

REV	DESCRIPTION	DATE	APP'D	DRAWN	NOTES
01					

NOTES

TITLE
BZ482G 5.2kW GENSET

DIMENSIONS IN MM (INCH)
DO NOT SCALE

MATL:



BETA MARINE LTD.
DAVY WAY,
WATERWELLS,
QUEDGELEY,
GLOUCESTER, GL2 2AD, UK

DRAWN BY:- TW
CHECKED BY:- LT

SIZE A4
SCALE NTS

DWG NO. 100-05655
PAGE 1 of 1

REV 02
DATE 25/08/2007

TEL: (01452) 723492 FAX: (01452) 729916