

ENGINE COMPARISON 4 CYLINDER

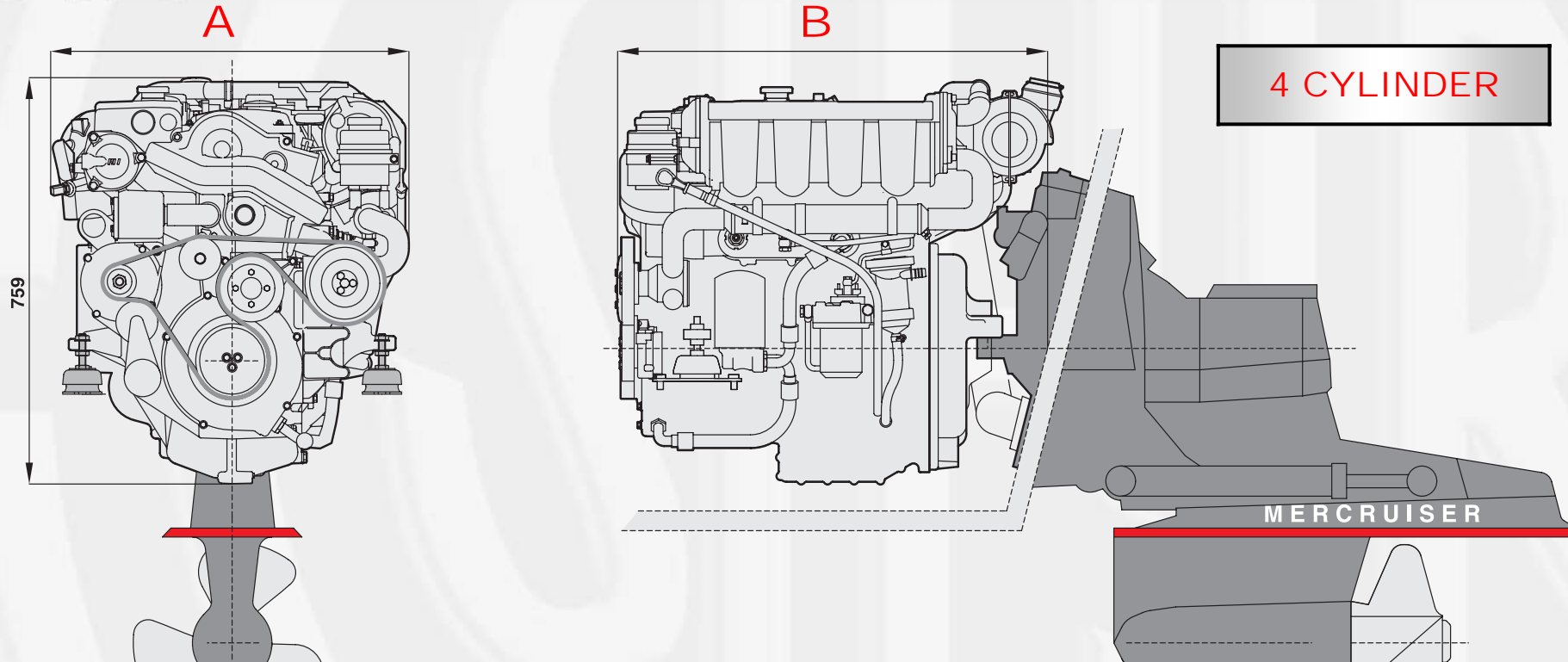

	A mm (inch)	B mm (inch)	Weight kg (lb)	kg / PS	lb / HP
STEYR 184 (176 HP)*	684 (26,93)	847 (33,35)	372 (820)	2,11	4,66
NANNI 4.380 TDI (175 HP)*	684 (26,93)	1020 (40,16)	430 (947)	2,46	5,41
VW TDI 150-5 (150 HP)*	760 (29,92)	854 (34,02)	383 (844)	2,55	5,63
CMD 2.8 ES (165 HP)*	762 (30)	1041 (40,98)	497 (1095)	3,01	6,54

* Crankshaft power

ENGINE COMPARISON 6 CYLINDER

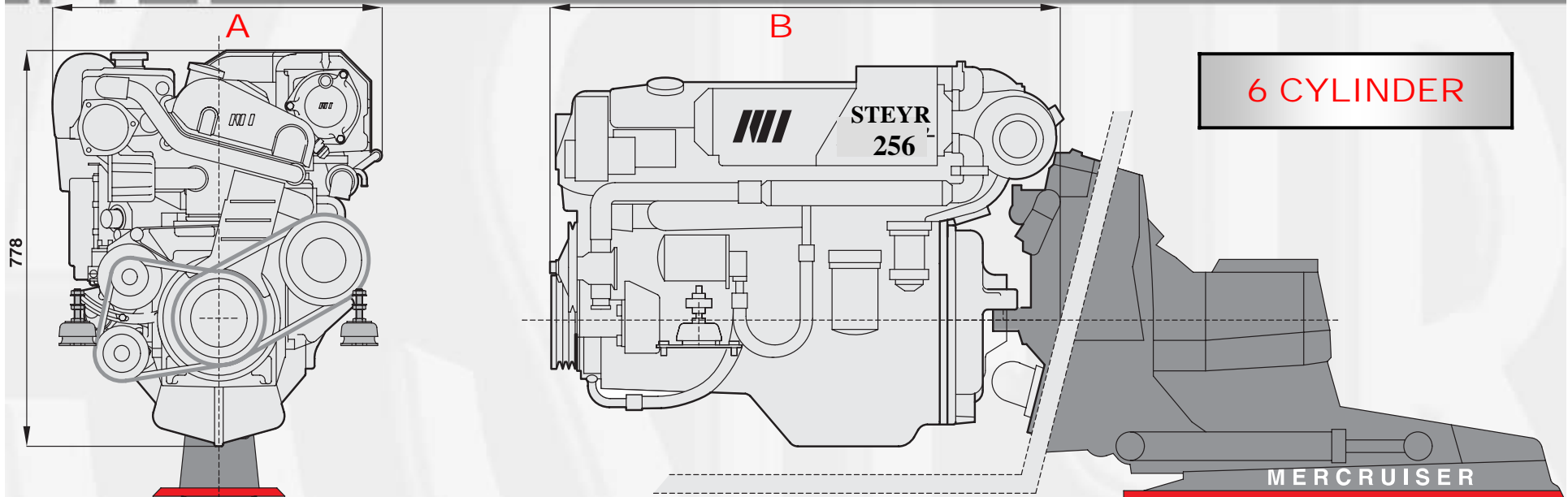

	A mm (inch)	B mm (inch)	Weight kg (lb)	kg / PS	lb / HP
STEYR 256 (250 HP)*	669 (26,34)	1033 (40,67)	427 (940)	1,71	3,76
YANMAR 6LPA-DTZE (260 HP)*	699 (27,52)	1145 (45,08)	516 (1137)	1,98	4,37
YANMAR 4LHA-STZP (240HP)* 4cyl.	785 (30,91)	1038 (40,86)	486 (1071)	2,03	4,46
NANNI 4.390 TDI (200 HP)*4 cyl	684 (26,93)	1020 (40,16)	445 (981)	2,23	4,91
CMD 4.2 EI (250 HP)*	762 (30)	1270 (50)	588 (1296)	2,35	5,18
VOLVO D6 (310 HP)*	153 (26,65)	1218 (47,95)	750 (1653)	2,42	5,33
VOLVO D4 (210 HP)*	153 (26,65)	982 (38,66)	644 (1419)	3,07	6,76

* Crankshaft power