

**6LY3-STP Series**

Configuration	24 valve, 4-stroke, vertical, water-cooled diesel engine	
Maximum output at crankshaft	324 kW@3300 rpm	[440 mhp@3300 rpm]
Displacement	5.813 ltr	[354 cu in]
Bore x stroke	106 mm x 110 mm	[4.17 in x 4.33 in]
Cylinders	6 in line	
Combustion system	Direct injection	
Aspiration	Turbocharged with seawater cooled intercooler	
Starting system	Electric starting 12V - 3 kW	
Alternator	12V - 80A	
Cooling system	Fresh water cooling by centrifugal fresh water pump and rubber impeller seawater pump	
Lubrication system	Enclosed, forced lubricating system	
Direction of rotation [crankshaft]	Counterclockwise viewed from flywheel side	
Dry weight without gear	640 kg	[1411 lbs]
Environmental	EU: RCD	EMC
	US: EPA Tier2	
	IMO: MARPOL 73/78 Annex VI	
Engine mounting	Rubber type flexible mounts	

NOTE:

Fuel condition: Density at 15°C = 0.86 g/cm<sup>3</sup>; 1 kW = 1.3596 mhp = 1.3410 HP

Fuel temperature 40°C at the inlet of the fuel injection pump [ISO 8665: 2006]

Technical data is according to ISO 8665: 2006/3046-1

DIMENSIONS

Front view

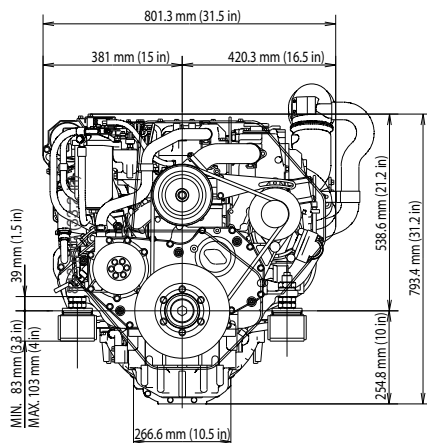

Right side view

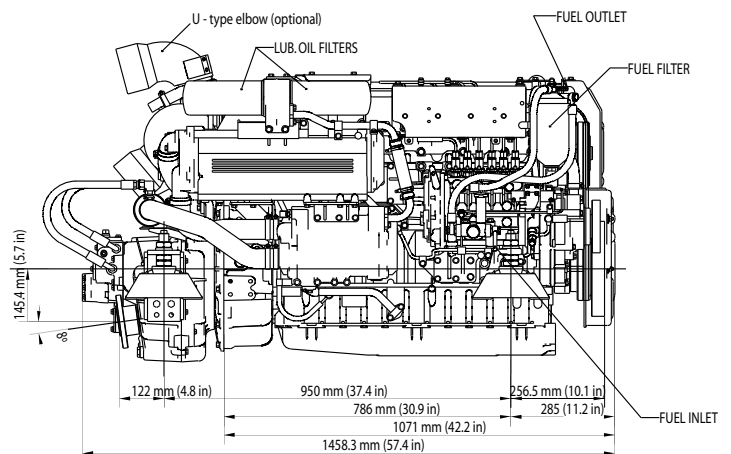

6LY3-STP with Yanmar KMH61A marine gear

## PERFORMANCE CURVES

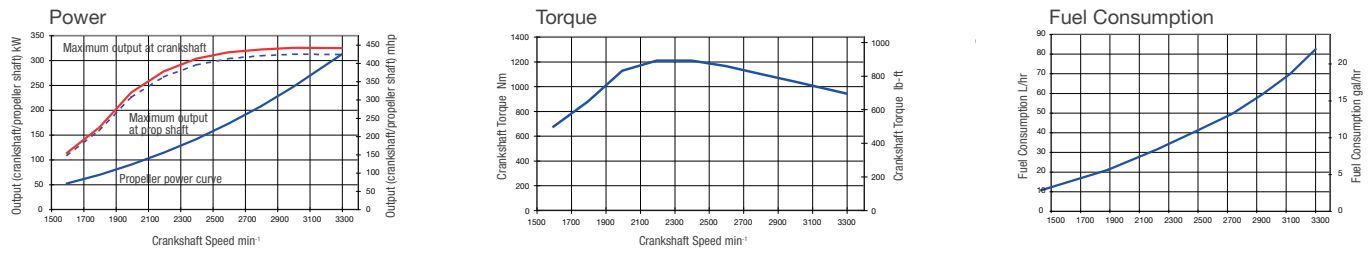

## MARINE GEARS / DRIVE

Model	KMH61A			KMH61V			
Type	Hydraulically actuated multi-disc clutch			Hydraulically actuated multi-disc clutch			
Dry weight	78 kg [172 lbs]			83.9 kg [185 lbs]			
Reduction ratio [fwd/asn]	1.55/1.55	2.04/2.04	2.43/2.43	1.24/1.24	1.49/1.49	1.98/1.98	2.43/2.43
Propeller speed [fwd/asn]	2129/2129	1618/1618	1358/1358	2661/2661	2215/2215	1666/1666	1358/1358
Direction of rotation [propeller shaft - fwd]	Clockwise & Counterclockwise viewed from flywheel side			Clockwise & Counterclockwise viewed from flywheel side			
Dry weight engine and gear/drive	718 kg [1583 lbs]			723.9 kg [1596 lbs]			

\* Other marine gearboxes and configurations available upon request. Contact your local supplier for more information.

## INSTRUMENT PANELS

Various Control heads



Multi function LCD display



CAN Bus system

- Multi function LCD display:
- engine information
  - maintenance information
  - diagnosis messages



Engine ECU Interface

## ACCESORIES

### Standard engine package

- Standard engine package
- Exhaust mixing elbow [L-type]
- Air heater

### Optional engine package

- Fuel/water separator
- High-riser mixing elbow [instead of L-elbow]
- Lub oil evacuation pump
- Remote oil filter opposite side
- Air vent for coolant tank
- Flexible mounts

## ELECTRONIC CONTROL SYSTEM

### Standard electronic control system

- CANBUS-NMEA 2000 electronic control system
- Ignition panel with rocker switches
- Multi-function LCD display
- Electronic control head

### Optional electronic control system:

- Second station kit for flybridge
- Ignition panel with keyswitch
- Extension wire harnesses
- Various control heads
- Trolling mode kit

NOTE: All data subject to change without notice. Text and illustrations are not binding.